



# Chilled vertical cabinets GRANVISTA INTEGRAL WL



## Product categories



## Technical features





GRANVISTA INTEGRAL WL						
<b>Lenght</b> -Lunghezza Longueur-Länge-Longitud mm		<b>1250</b>	<b>1875</b>	<b>2500</b>	<b>1875</b>	<b>EOL 1960</b>
Altezza mm		20	20	20	20	20
	<b>Compact</b>	•	•	•	•	•
	<b>Narrow</b>	•	•	•	•	•
<b>Display area</b> Superficie di esposizione Warenpräsentationsfläche Surface d'exposition Superficie expositiva m2	<b>Compact</b>	2.05	3.07	4.10	6.14	4.15
	<b>Narrow</b>	2.11	3.16	4.22	6.32	4.59
<b>Loading area</b> Superficie di appoggio Nutzfläche Surface de chargement Superficie de apoyo m2	<b>Compact</b>	1.03	1.54	2.06	3.08	1,61
	<b>Narrow</b>	1.21	1.82	2.42	3.64	1.91
<b>End thickness</b> Spessore spalla Stärke der Seitenwand Épaisseur de chaque joue Espesor lateral mm	30.00 (+ 35 Bumper Rail)					

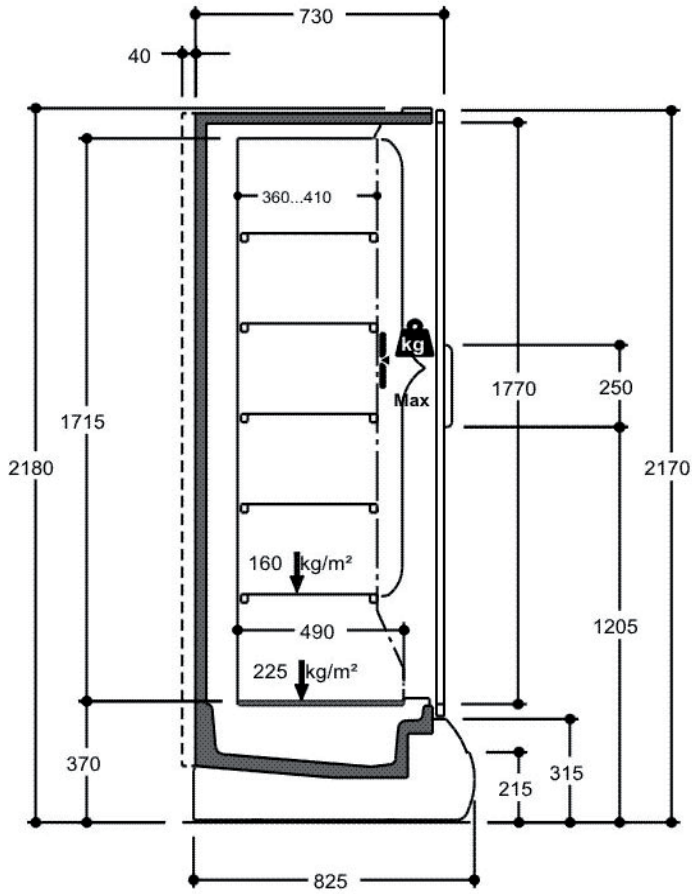





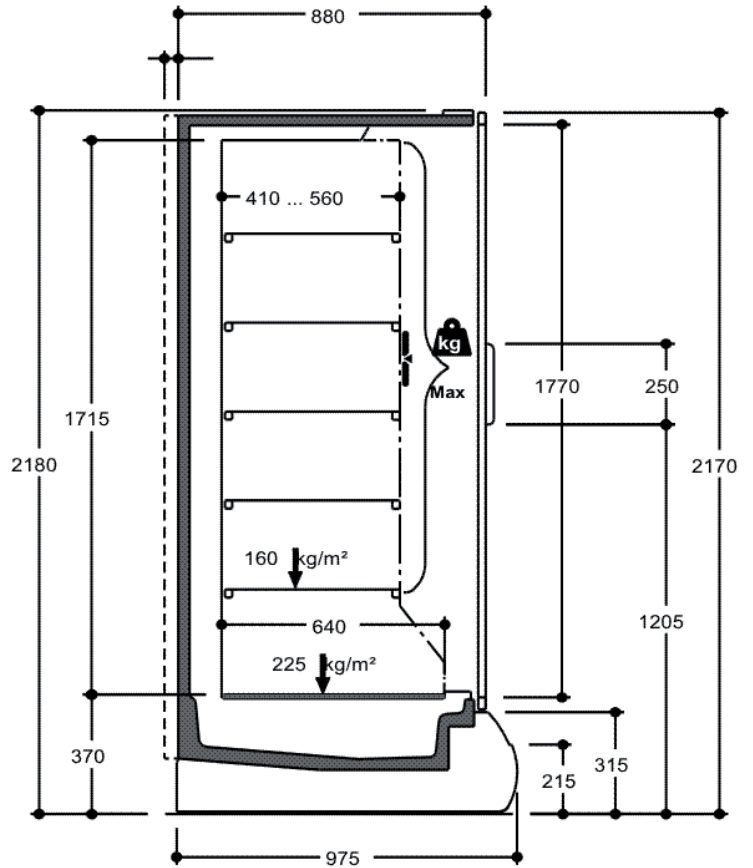













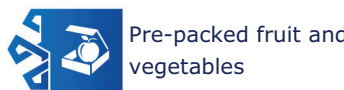



























COMPACT

NARROW

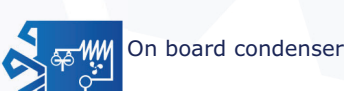



## Legend

 Meat	 Chicken	 Fish	 Pre-packed fish
 Delicatessen	 Cheese	 Dairy products	 Gastronomy
 Pastries	 Pre-packed fruit and vegetables	 Fruits and Vegetables	 Sandwiches
 Drinks	 Pizza	 Bread	 Frozen food and ice cream
 Off-cycle defrost	 Electric defrost	 Hot-gas defrosting system	 Manual defrost
 Ventilated	 Static	 Incorporated condensing unit	 Remote condensing unit
 Bagnomaria	 Ceramic glass	 Ice	 VSD Inverter technology
 LED lighting	 Zero C doors	 High efficiency fans	 R290 Propane refrigerant gas (R290)
 R134a R-134a - 400V/3PH/50Hz	 R404A R404A - 400V/3PH/50Hz	 R744 R744 - 400V/PH/50Hz	 Compressor hermetic reciprocating
 Hermetic scroll compressor	 Semi-hermetic reciprocating compressor	 VSD Inverter technology	 External installation
 Machinery room	 Soundproof housing	 On board condenser	 Remote condenser
 DUAL Medium & Low temperature	 Technokleen	 Thin Tech	 EB