

ECO₂ MIDDLE

MT from 60 to 150 [kW]

LT from 0 to 50 [kW]



SUPERMARKET



ETE



FTE



TUV AUSTRIA CERTIFIED

EN ISO 9001
20 100 52000877
EN ISO 14001
20 104 141373322
OHSAS 18001
20 116 141373323



Range of Power Packs CO₂

- CO₂ transcritical unit.
- Very compact product
- Modular design for manutention and complex installation.
- Booster BLTand MT.
- High pressure oil solution from EPTA.
- **ETE** and **FTE** performing systems available on this platform
- Easy maintenance concept

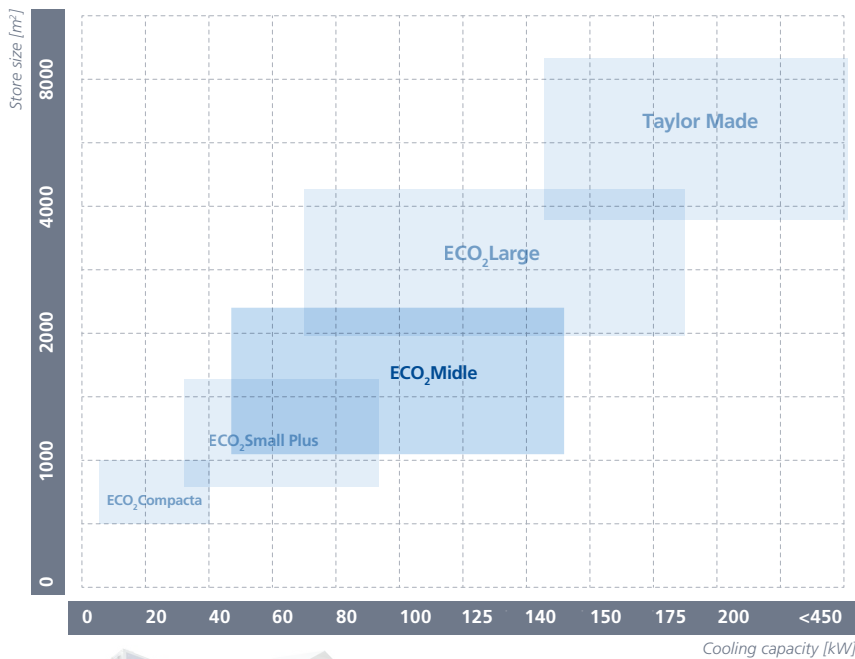

Technical Information

Compressors BITZER	MT3 + LT3	MT4 + LT3
Number of MT compressor	max 3	max 4
Number of LT compressor	max 3	max 3
Number of ETE compressor	max 1 <i>(total MT+ETE = maxi 3)</i>	max 1 <i>(total MT+ETE = maxi 4)</i>
Smallest MT compressor	4PTE-7K	
Biggest MT compressor	4DTE-25K	
Smallest LT compressor	2MSL-07K	
Biggest LT compressor	2DSL-5K	
Smallest ETE compressor	4PTE-7K	
Biggest ETE compressor	4HTE-20K	

General		
Power supply	3P+T400 V (50Hz)	
Short-circuit current (kA)	35 kA (standard)	
Max weight	1450 kg	1750 kg
Liquid receiver volume	200 l	
Estimated sound pressure level (max)	59 dB(A)@10m	60 dB(A)@10m
Sound power level (-10°C/90 bar)	86,8 dB(A)	88 dB(A)
Installation	Indoor version	

Pressure service	
High pressure	120 bar
Suction MT	45/53/60 bar
Suction LT	30/60 bar
Suction ETE	100 bar
Suction Liquid line	45/53/60 bar
Oil circuit	120 bar

Components and options

ACCESSORIES	BASIC	OPTIONAL
SECURITY PACK		
Double flash gas valve (1 back-up)		•
Double transcritical valve (1 back-up)		•
Back-up regulator		on request
ULTRACAP or UPS integrated		•
UPS predisposition	•	
Liquid injection MT	•	
Hot gas injection MT	•	
Hot gas injection LT	•	
Safety valve on manifold		•
Doble safety valve on remote rack	•	
Alarm liquid level		•
Air desuperheater for LT outlet		•
Exchanger for back-up unit		•
Back-up R134a unit remote		•
Back-up R744 unit onboard		•
MAINTENANCE PACK		
Filter suction MT	•	
Filter suction LT	•	
Filter on oil line	•	
Liquid line with dryer repacable cartridge	•	
By-pass oil separator		•
By-pass liquid line	•	
Predisposition for ICE SMART		•
PERFORMANCE PACK		
CR II IQ module		•
Inverter MT/LT	•	
ETE remote		•
FTE remote		•
LSPM motor on 1st MT compressor		•

ACCESSORIES	BASIC	OPTIONAL
ELECTRICAL PANEL		
Differential protection		•
Emergency push button		•
Electrical counter		•
Display		•
SWITCH ON PACK predisposition	•	
Inverter MT / inverter LT 1st compressor	•	
DANFOSS regulator	•	
CAREL regulator	•	
WURM regulator		on request
MECHANICAL		
Housing		on request
Noise insulation on housing.		on request
Feet with absorbers feet.	•	
EXCHANGERS		
Exchanger for heat recovery remote		•
Economizer (exchanger out GC / flash gas)		on request
Auto subcooler for liquid line with regulation.		on request
Auto subcooler for liquid line (exchanger liquid line / flash gas)		on request
Subcooler outlet gas cooler exchanger		on request

Dimensions

MT3 + LT3 or MT2//ETE1 + LT3

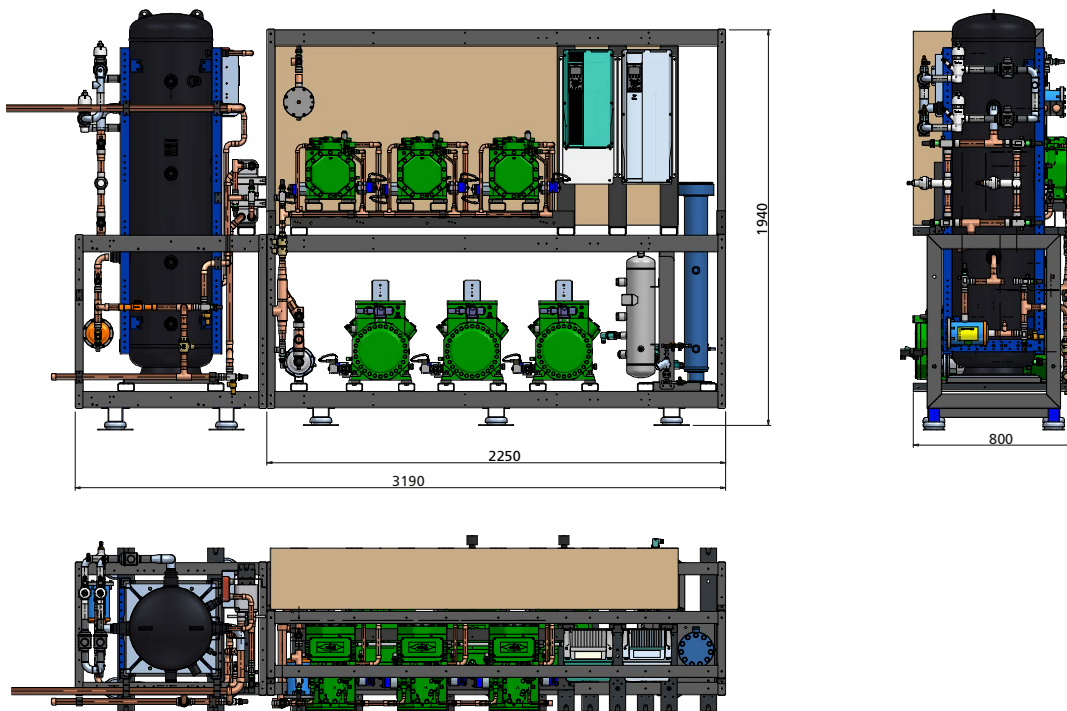

Dimensions

MT3 + LT3 or MT3//ETE1 + LT3 WITHOUT LIQUID RECEIVER

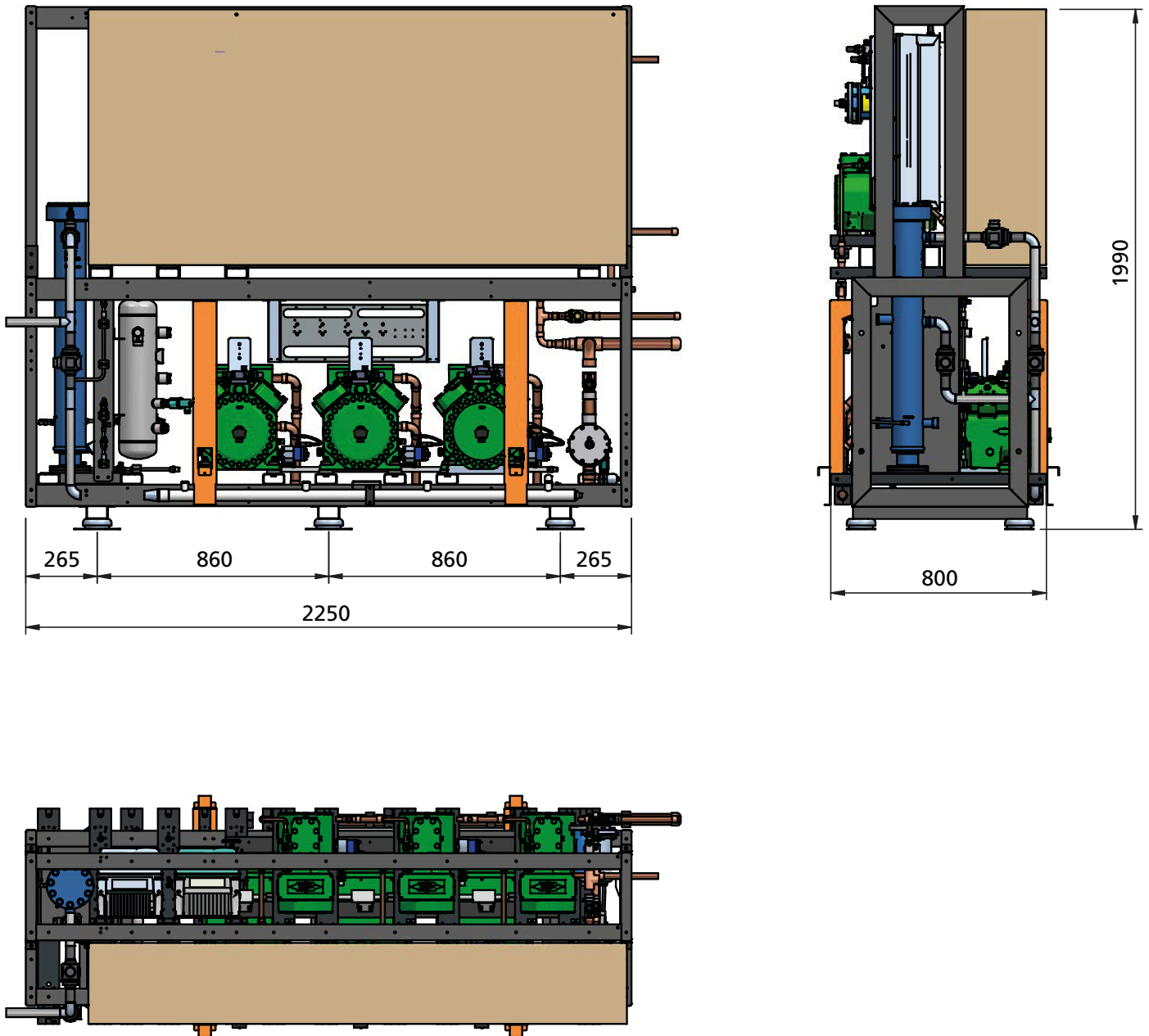

Dimensions

MT4 + LT3 or MT3//ETE1 + LT3

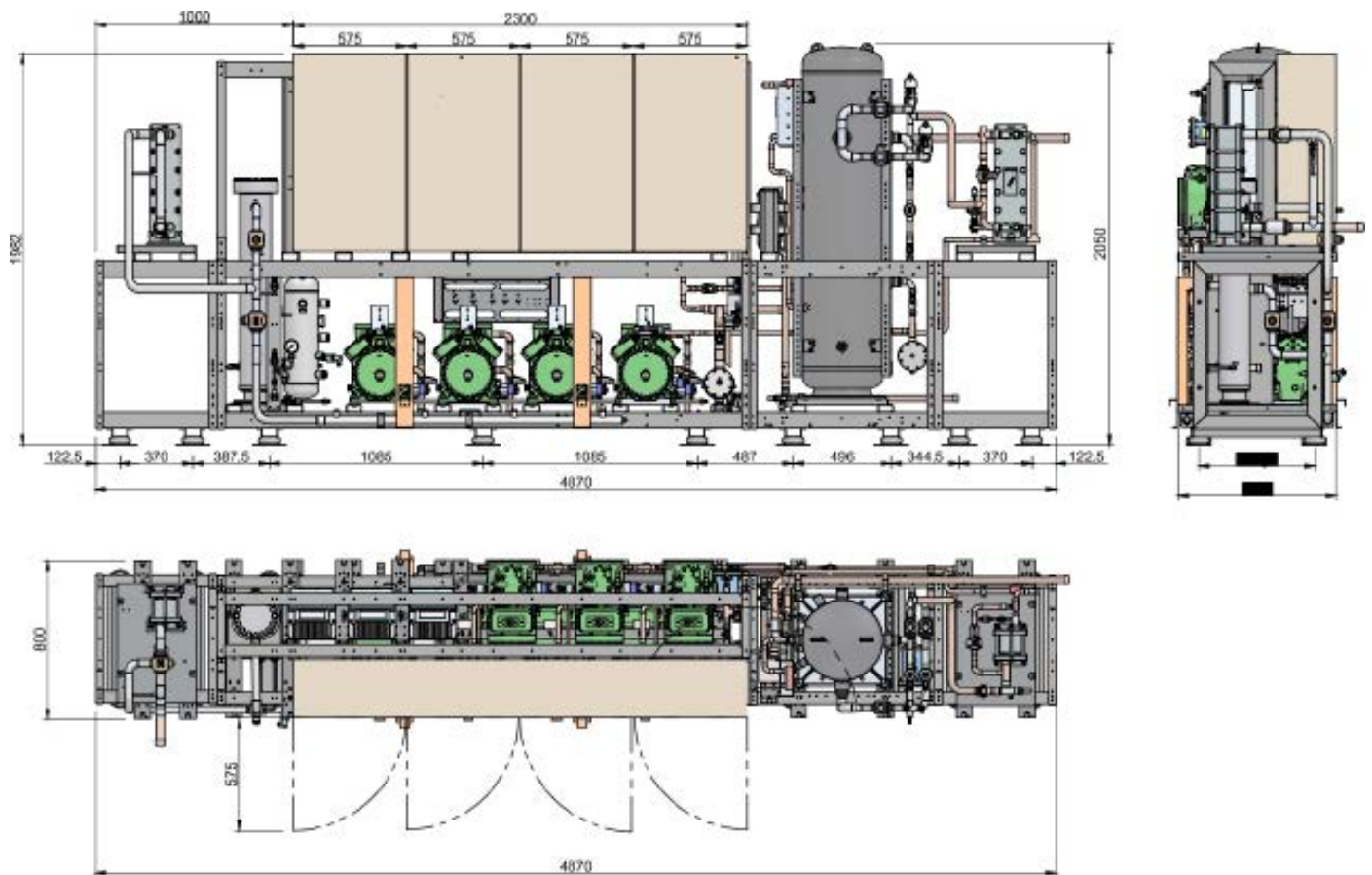

Dimensions

MT4 + LT3 or MT3//ETE1 + LT3 WITHOUT LIQUID RECEIVER

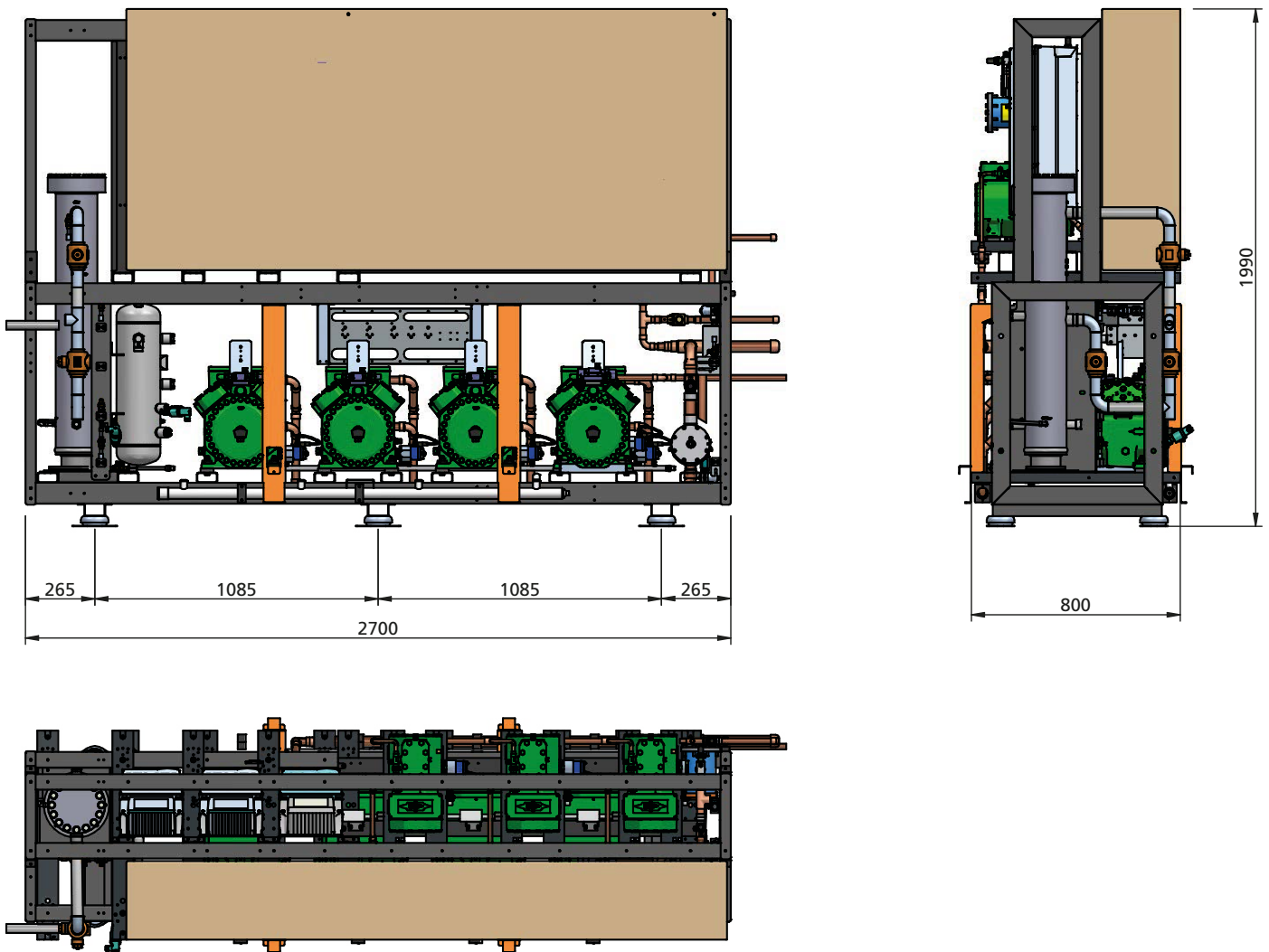

Dimensions

LIQUID RECEIVER REMOTE

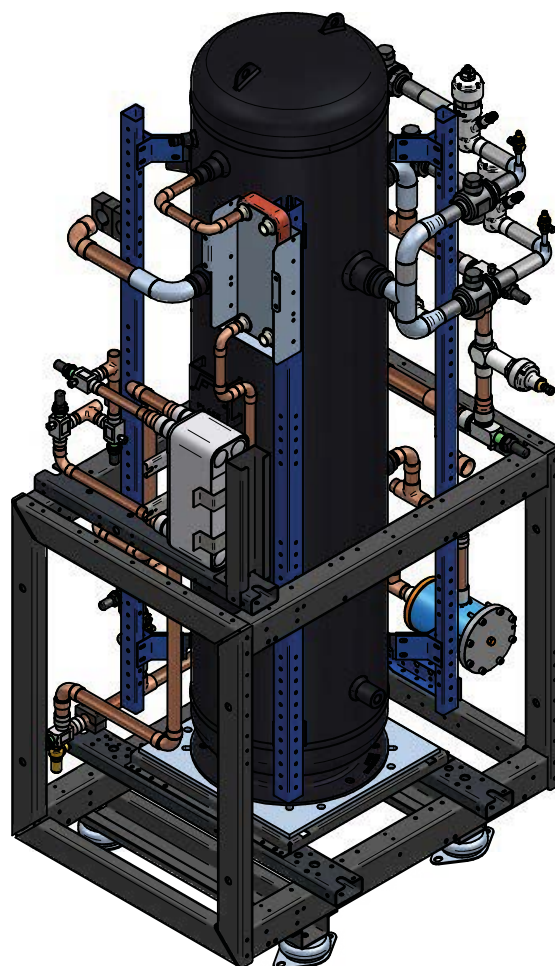
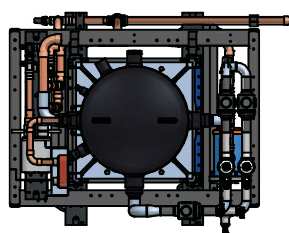
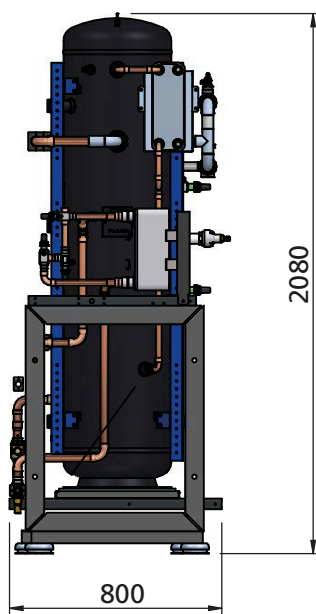
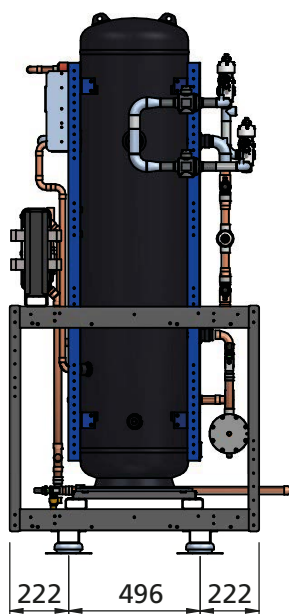

Dimensions

ETE MODULE

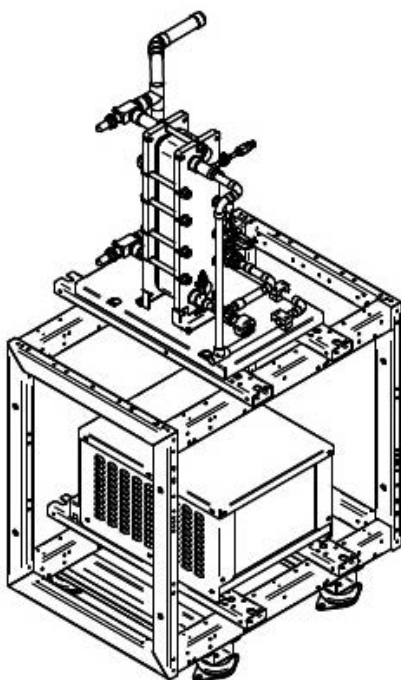
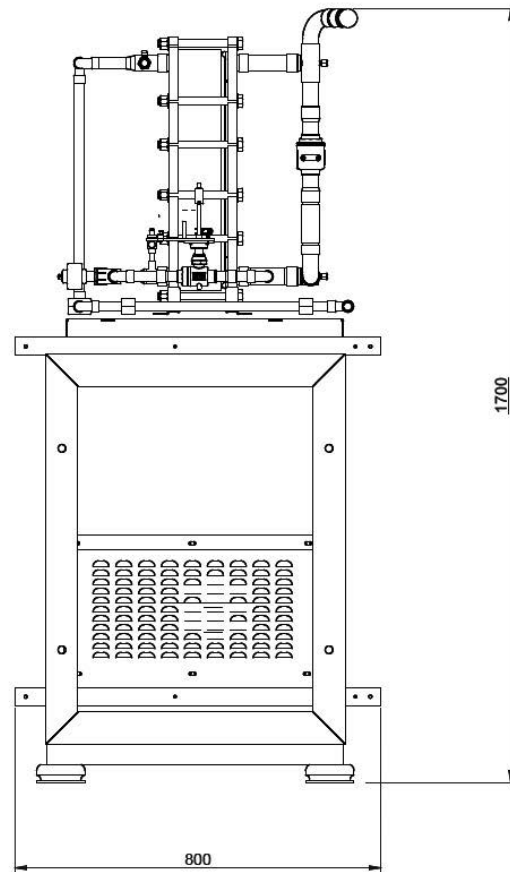
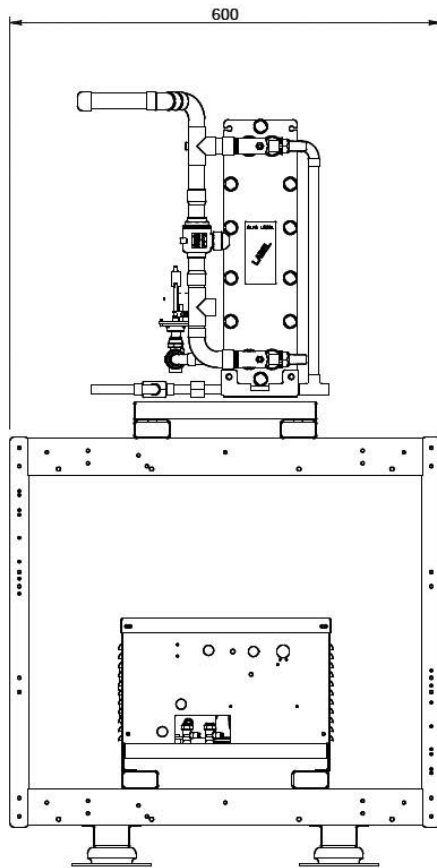

Dimensions

HEAT RECOVERY MODULE

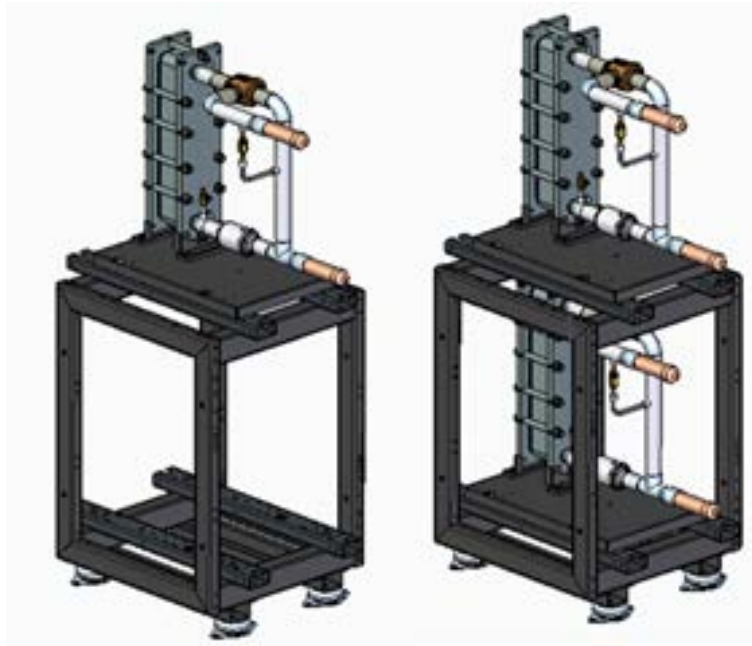

Remote elements	Dimensions		
	Depth (mm)	Length (mm)	height (mm)
EXCHANGER HR TAP WATER	800	600	1700
EXCHANGER ETE	800	600	1700
ECONOMIZING EXCHANGER	800	600	1700