

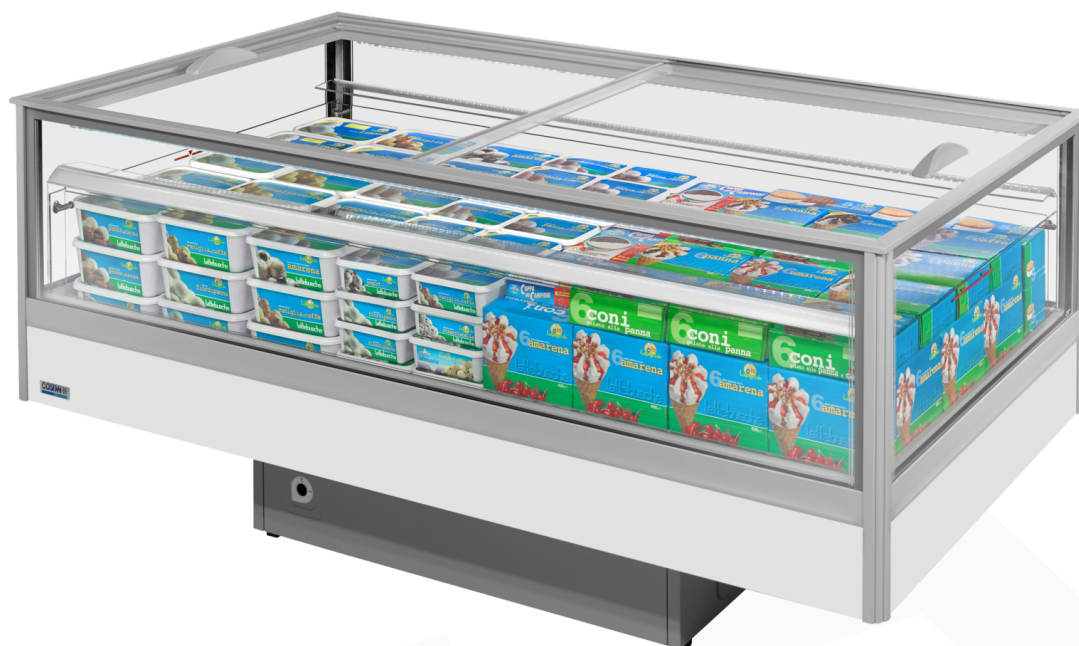

Groupe logés CHORUS



Catégories de marchandises



Caractéristiques techniques





CHORUS					
CHORUS	CLOSED			OPEN	
	BT/TN			TN	
	100	1500	2000	1500	2000
	•	•	•	•	•
Surface d'exposition m ²	1.36	1.96	2.56	1.96	2.56
Surface de chargement m ²	1.00	1.50	2.00	1.50	2.00
Volume utile dm ³	199.00	311.00	423.00	311.00	423.00
Longueur mm	1000x925x1000	1500x925x1000	2000x925x1000	1500x925x1000	2000x925x1000
Hauteur mm					
Profondeur mm					



BT/TN - LT/MT

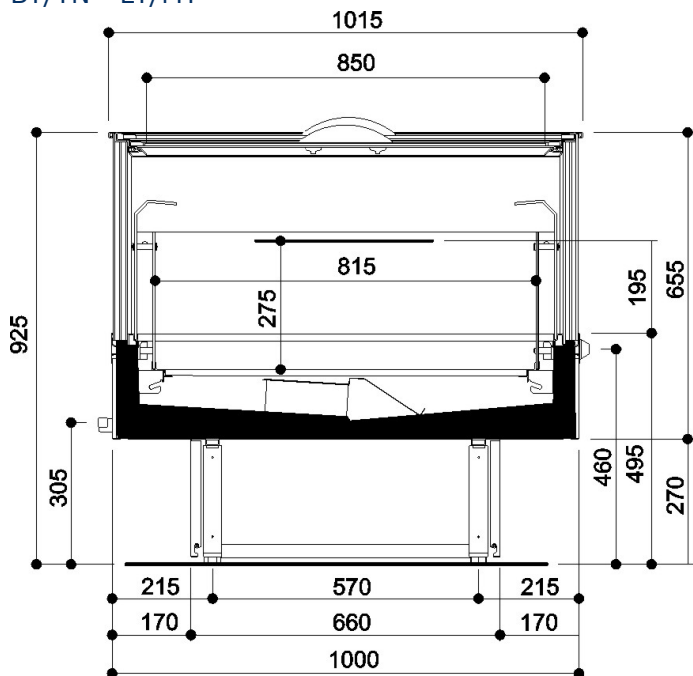

TN - MT

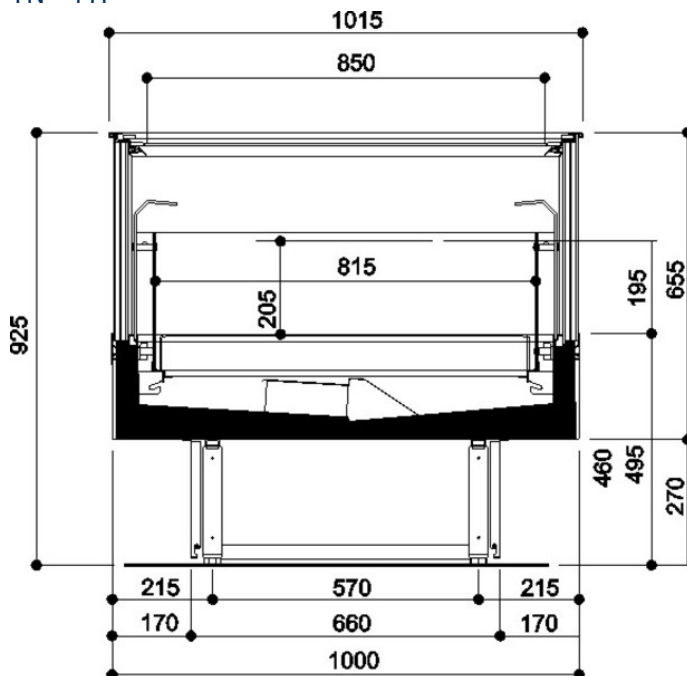



Légende

 Viande	 Volailles	 Poisson	 Poisson pré-emballé
 Charcuterie	 Fromage	 Produits laitiers	 Traiteur
 Pâtisseries	 IV gamme	 Fruits et Légumes	 Sandwiches
 Boissons	 Pizza	 Boulangerie	 Surgelés et crème glacées
 Dégivrage naturel	 Dégivrage électrique	 Dégivrage par gaz chaud	 Dégivrage manuel
 Ventilé	 Statique	 Groupe de condensation incorporé	 Groupe de condensation à distance
 Bain-marie	 Plaque Vitrocéramique	 Glace fondante	 VSD Technologie avec variateur de vitesse
 Eclairage LED	 Portes Zéro C	 Ventilateurs Basse Consommation	 R290 Réfrigérant propane (R290)
 R134a R-134a - 400V/3PH/50Hz	 R404A R404A - 400V/3PH/50Hz	 R744 R744 - 400V/PH/50Hz	 Compresseur hermétique alternatif
 Compresseur hermétique scroll	 Compresseur semi-hermétique alternatif	 VSD Technologie avec variateur de vitesse	 Utilisation externe
 Salle des machines	 Insonorisation	 Condenseur intégré	 Condenseur déporté
 DUAL Moyenne et basse température	 TECHNOKLEEN Technokleen	 THIN TECH Thin Tech	 EB