

NORDICLINE FL2 PI AIDA

Serve-over cabinet



Premium presentation of all frozen products.

NordicLine FL2 PI Aida is an innovative display range where design meets functionality and the latest technology meets eco-friendly ideals.



Increase sales with an eye-catching display



The best technical performance in its class

NordicLine FL2 PI Aida has been developed to meet the most demanding customer needs and truly has it all – from outstanding design to superior technical details. Environmentally friendly refrigerant R290 is standard for most models.

Efficient use of floor space

NordicLine FL2 PI Aida is a versatile, easy to maintain and eco-friendly range of display cabinets for pastry, snacks and other delicacies. Several cabinet models from service to self-service and different colour options make it a perfect fit for a convenience store or any shop floor or café, no matter how small. New self service models with glass covers offer a fast and convenient way for shoppers to do their purchase.

NordicLine FL2 PI Aida has plenty of shelf space. Glass shelves and two front glass options make for great product visibility. This versatile display family truly is a masterpiece.

NordicLine FL2 PI Aida is available as a plug-in cabinet.

CHOOSE NORDICLINE FL2 PI AIDA FOR

- Versatile with several models from serve-over cabinets to bake off and self service models
- R290 as refrigerant
- Fits any store concept with wide range of glazing units
- Effortless usage for both customers and staff
- Beautiful styling and lighting present the most delicious looking products
- Easy maintenance and cleaning

TECHNICAL SPECIFICATIONS



NordicLine FL2 Aida

External length (mm)	490
External length (mm)	600, 900, 1200, 1500 (ambient)
External height (mm)	1340
External depth (mm)	755
Temperature range (°C)	Serve-over, bake-off: -1 to +7, Self service: -1 to +10 Corner unit: +4 to +8, Hot counter: +65 to +80 / +45 to 60
Refrigerants	R290
Energy efficiency class	

NordicLine FL2 PI Aida SO-RG -1 to +7

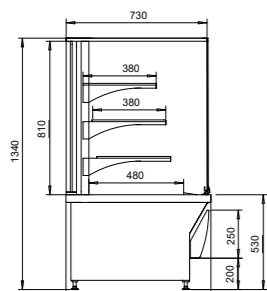

NordicLine FL2 PI Aida SO-CG -1 to +7

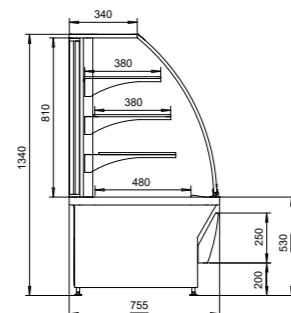

TECHNICAL SPECIFICATIONS / ACCESSORIES

NordicLine FL2 PI Aida BO-RG -1 to +7

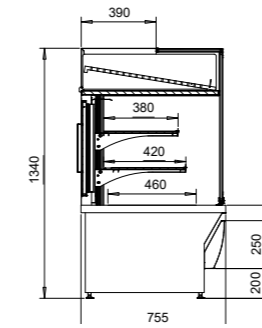

NordicLine FL2 PI Aida BO-CG -1 to +7

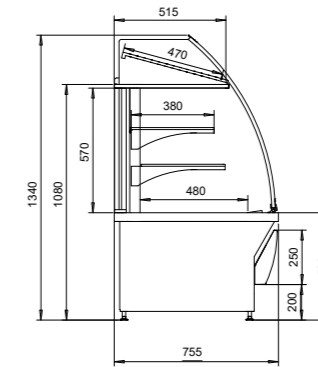

NordicLine FL2 PI Aida SF-CG -1 to +10

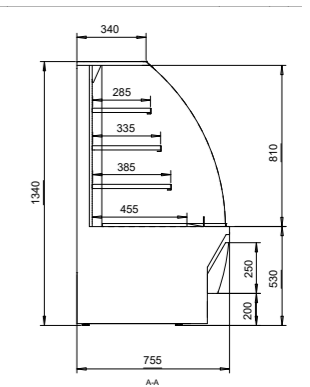

NordicLine FL2 PI Aida SOSF-RG -1 to +10

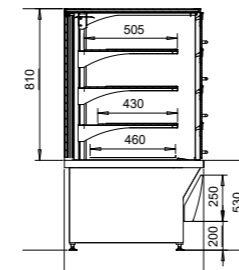

NordicLine FL2 PI Aida H +65 to +80 / +45 to +60

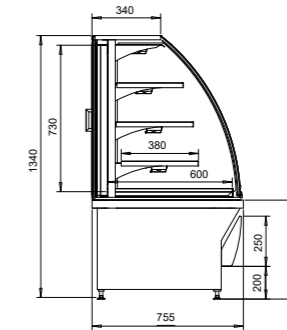

STANDARD EQUIPMENT

- R290 refrigerant
- Integrated LED lights
- Adjustable glass shelves up to 15,5°
- Hot gas defrost water evaporation
- Double thermo glass
- Insulated base
- Cassette refrigeration unit
- Control device
- Three body colours: gold, black, stainless steel
- Three front panels: oak, black, stainless steel

OPTIONAL ACCESSORIES

- Castors
- Multiplexing end panel
- GN pan shelves and GN pans
- Special cake trays
- Shelf front stopper trim



Back door bake-off models



Glass cover for self service models

BENEFITS

Great product visibility with
panorama ends and glass shelves



Attractive integrated LED
lights increase sales
and impulse purchases

Easy to maintain and service



With a versatile range of models, NordiLine FL2 PI Aida easily adapts to different retail environments from small convenience stores to supermarkets.



www.costan.com

Follow us on:     by Epta